



## >> Solutions for Wear Protection in Mining and Processing Industry



# >> Work with Kalenborn for Your Optimal Solution

## Reduce Costs and Avoid Downtimes

Large quantities of bulk materials are handled in the conveying and storing systems operated for coal, ore and mineral mining as well as in raw material processing.

Kalenborn offers a complete array of wear protection materials, including not only ceramic and metallic materials, but also plastics and rubber.

In addition, Kalenborn has extensive experience in the field of slide promotion. Interruptions of material flow inside of bunkers and silos must be avoided.



Proper wear protection of hydrocyclones extends the service life of the equipment and reduces the cost of downtime

### Advantages of Lining Materials:

#### Ceramic Wear Protection

- Very good abrasion resistance
- Tile, cylindrical or jointless lining
- Temperatures up to 1,000 °C/1,832 °F

#### Metallic Wear Protection

- Good resistance against sliding and impact wear
- Thin walls, self-supporting structures
- Good thermal shock resistance

#### Technical Plastic Lining

- Excellent slide promotion for many application
- Good resistance against impact wear
- Low weight

#### Material Combinations

- Optimal wear protection for every application
- Optimized lining cost
- Optimized weight

Screw conveyor protected with hard cast iron KALCAST. Depending on the alloy, a very high abrasion and impact resistance is achieved.



# >> Pipes, Components and Service

## Optimal Solution for every Plant Component

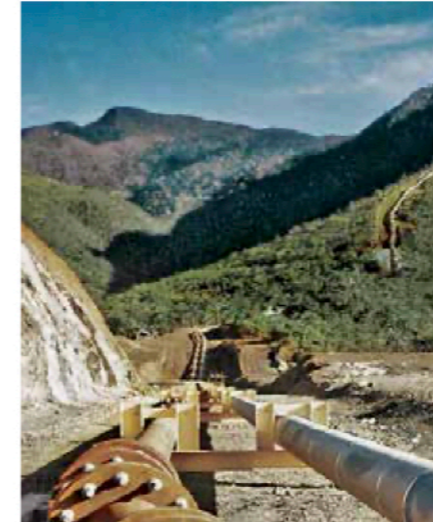

Extended service life of plant components



Hydraulic and pneumatic pipes



Kalenborn service solves wear problems on site

### Wear protection in mining increases the lifetime of the plants

Plant components are at risk in all sections of mining and processing. This is true not only for mines and quarries but also for size reduction and classifying systems as well as for hydraulic raw material handling and the separation of tailings. Pelletizing plants also require special protection as do dust collection and drying systems.

The following brand names are used for the materials:

- ABRESIST fused cast basalt
- KALCOR zirconium corundum
- KALCOR S sintered zirconium corundum
- KALOCER high-alumina ceramics
- KALCERAM wear-resistant hard ceramic
- KALCRET hard compound
- KALSICA silicon carbide ceramics
- KALCAST hard casting
- KALMETALL hard overlay welding
- KALEN slide promotion plastics

In addition, material combinations have been very successful in practice. They enable both technically and economically optimal solutions.

### Wear Protected Components

Components	Lining Materials
Cyclones	ABRESIST, KALCOR, KALOCER, KALSICA, KALMETALL
Fan housings	KALOCER, KALCRET, KALMETALL, KALCAST
Fan rotors	KALOCER, KALMETALL
Gates	KALOCER, KALCOR, KALSICA, KALMETALL, KALCRET
Hydraulic conveyors	ABRESIST, KALMETALL, KALCAST, KALOCER, KALCRET
Nozzles	KALOCER, KALSICA
Pneumatic conveyors	ABRESIST, KALOCER, KALCRET, KALMETALL, KALCRET
Pumps	KALSICA
Separators	ABRESIST, KALOCER, KALSICA, KALMETALL, KALCAST, KALCRET
Transfer stations	ABRESIST, KALEN, KALCERAM
Valves and fittings	KALOCER

# >> Solutions for Wear Protection for Mining and Processing

## RAW MATERIAL EXTRACTION

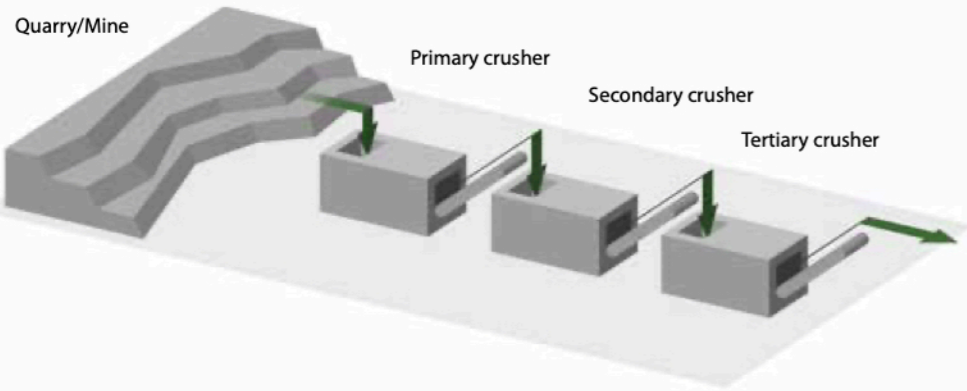

## PROCESSING

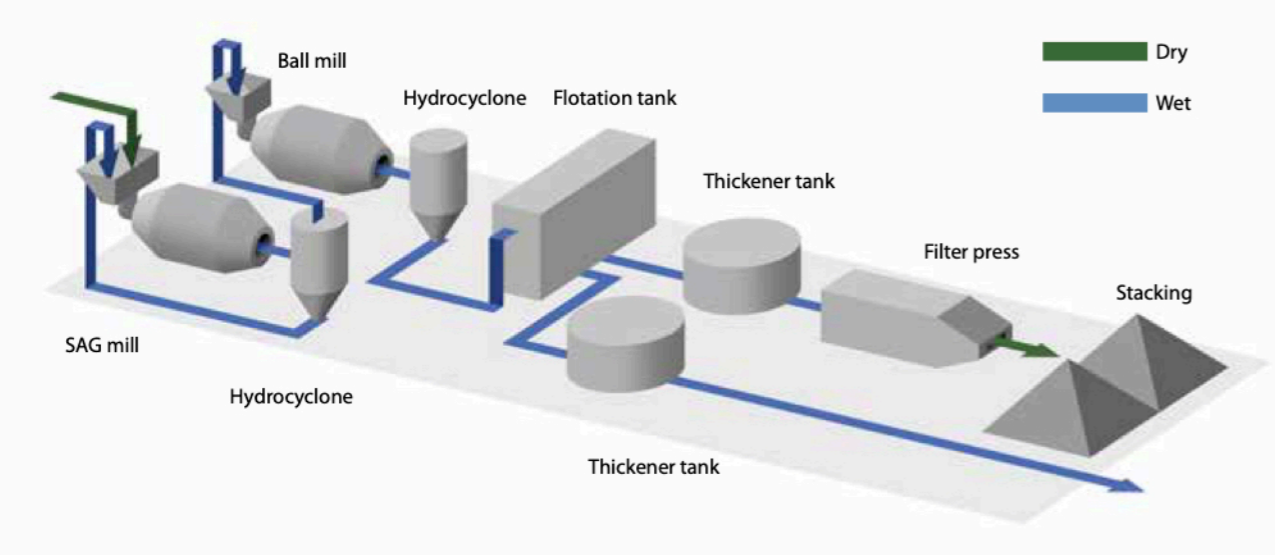

## TAILINGS

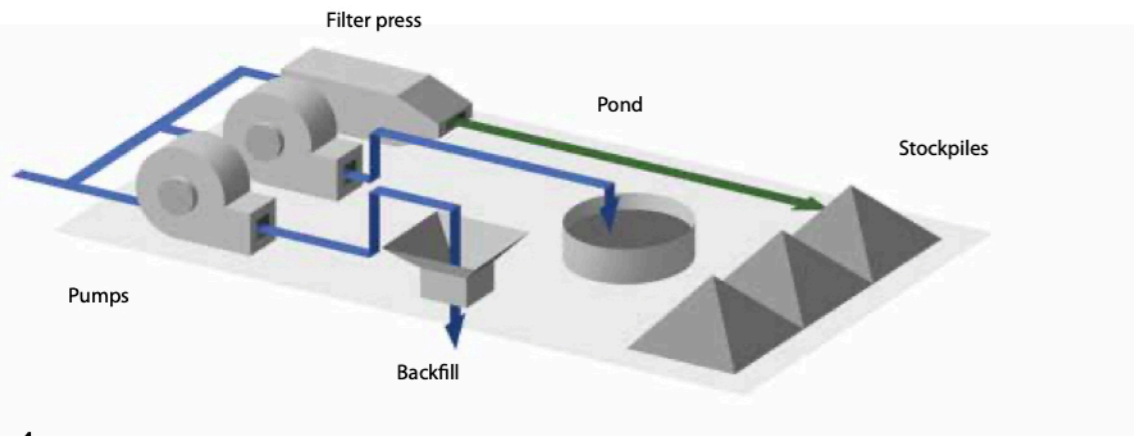

Plant	Components	Material for lining
Crusher	Housing, troughs, transfer chutes	KALCAST, KALMETALL, KALCOR, KALEN
Screening plant	Screen media, troughs, transfer chutes	KALCAST, KALMETALL, KALCOR, KALEN

Plant	Components	Material for lining
SAG mill	Transfer chutes, spout feeders	KALCAST, KALOCER, KALCOR
Ball mill	Spout feeders, lining	KALCAST, KALOCER, KALCOR
Hydrocyclones	Hydraulic piping, distributors, launders	KALOCER, KALSICA, KALCOR, KALCRET
Flotation tank	Hydraulic piping, flotation tanks, thickener tanks	ABRESIST, KALOCER, KALCOR, KALCRET
Dewatering/ filtration	Troughs, filter presses	ABRESIST, KALOCER, KALCERAM, KALEN
Stacking	Transfer chutes, troughs, silos, bunkers	ABRESIST, KALOCER, KALCERAM, KALEN

Plant	Components	Material for lining
Dewatering/ filtration	Troughs, filter presses	ABRESIST, KALOCER, KALCERAM, KALEN
Dry stacked tailings	Transfer chutes, troughs, stackers/reclaimers, silos, bunkers	ABRESIST, KALOCER, KALCERAM, KALEN, KALMETALL
Pumped tailings/ backfill	Mixers, launders, tanks, pumps, hydraulic piping	ABRESIST, KALOCER, KALCOR, KALCRET

# >> Wear Protection for Mining and Processing

## Solutions for Mine and Quarry



Special metallic materials are used for mines and quarries which offer both high abrasion resistance and efficient impact protection.



Loading shovels are subject to increased wear in quarries. Therefore, linings made of KALMETALL HB, KALMETALL and KALCAST provide good protection.



Dump trucks require special lining. KALMETALL is especially useful. KALINOX and KALEN are given preference for handling sticky materials.

**Die Standzeit von Rohrteilen mit Gummi- oder Kunststoff-Auskleidung ist in der Erzaufbereitung oft nicht ausreichend. Dies gilt insbesondere dann, wenn scharfkantiges Korn die Auskleidungen in kurzer Zeit zerstört.**

In these situations ceramic materials are better. Good experience has been gathered worldwide with ABRESIST fused cast basalt, KALCOR zirconium corundum and/or KALOCER high alumina ceramics.

**An example:** Lining of pipe parts of an iron ore mill in Brazil:

- sludge density 1.45 kg/dm<sup>3</sup>
- hard material portion 43 %
- iron ore portion 25 %
- high silicon percentage
- conveying velocity 5.6 m/s
- service life with rubber lining: 6 months
- service life with KALCOR zirconium corundum: > 8 years



In Brazil the rubber lining in the pipe from the grinding mill to the classifying of the iron ore failed after a short time. These pipes are now lined with KALCOR zirconium corundum.

## Protection for Size Reduction and Grinding Plant



For grinding mills Kalenborn offer solutions for material feeding and discharge. This applies to mechanical components and hydraulic conveying systems.



Pipe with KALCOR wear protection ensure long service cycles in the various areas of ore preparation.



The best possible protection for hydraulic pipes used in the classification of ores is ceramic materials. This can be ABRESIST, KALCOR or KALOCER.



Raw material bunkers must have a long service life. This will be assured by a 50 mm thick KALOCER lining.

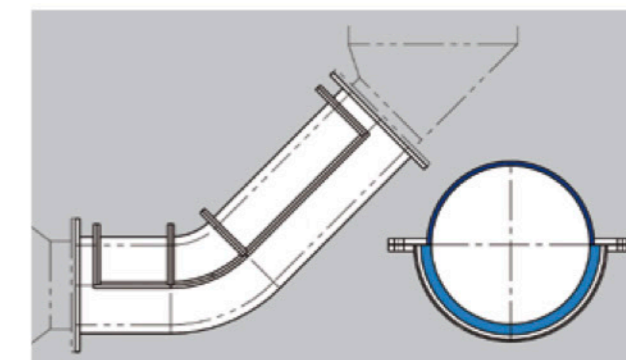

Mill feed section lined with replaceable wear segments made of KALCAST hard casting characterized by high impact resistance.

# >> Wear Protection for Mining and Processing

## Long Service Cycles Requested for Hydraulic Pipe



All over the world ores and tailings are successfully conveyed hydraulically. However, a precondition is an acceptable service life of pipes. This is achieved by the use of optimal materials like ABRESIST, KALCOR or KALOCER.

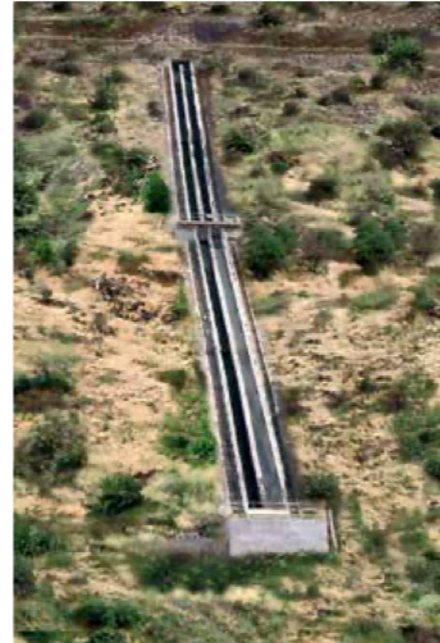

Hydraulic drop chutes can be operated over long periods provided they have been appropriately lined. ABRESIST fused cast basalt is often the preferred choice.



Highly wear resistant KALOCER pipes for handling ore sludge to be installed in a mine in the Far East.



Hydraulic conveying pipes integrated in a coal preparation plant in North America. The pipes have been lined with ABRESIST. In this case they reach service cycles of more than 20 years.

## Combinations of materials



Transport pipes subject to high impact load needing thin walls or limited weight are manufactured of KALMETALL hard overlay welded plates.



Pipes protected with KALCOR zirconium corundum installed in the discharge section of an iron ore grinding mill in Brazil. Rubber linings failed after a few months whereas the KALCOR lining has been in operation for several years.



Material combinations are an advantage for pipes of larger diameter. Here ABRESIST fused cast basalt has been combined with KALCOR zirconium corundum.



When extreme wear requires the use of KALOCER high alumina ceramics and the pipe diameter exceeds 200 mm, the best solution are pipe bricks.

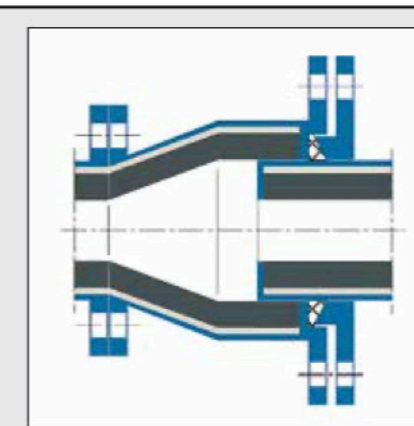

Due to the influence of temperature, hydraulic pipes cannot be laid over long distances without expansion joints. However, it is not only the compensation of length that counts. Another important requirement is that the service matches that of the plant as a whole. Therefore, Kalenborn supply expansion joints fitted with the same lining as the complete pipe system of the plant.

# >> Wear Protection for Mining and Processing

## Pumps and Distribution Systems



When the material handled is highly aggressive the pump axles also require safe protection: here KALOCER high alumina ceramics has been used.

Pumps used for hydraulic transport are subject to high wear. Kalenborn supply linings of KALOCER high alumina ceramics which significantly extend the service life of the pumps.

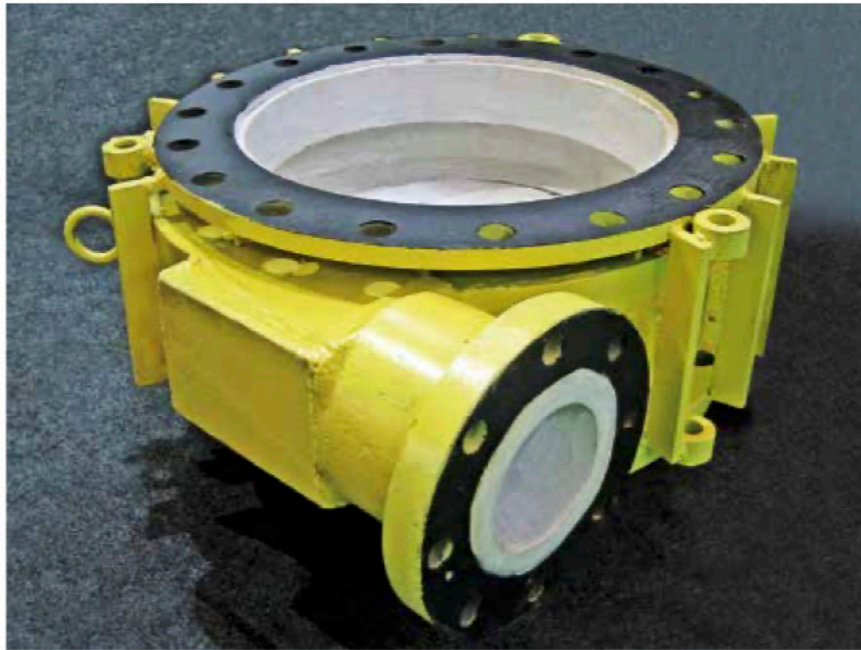

Quite often distributor housings are fitted with rubber lining. Short service cycles suggest ceramic linings: this problem will be solved best with ABRESIST, KALCOR and KALOCER.

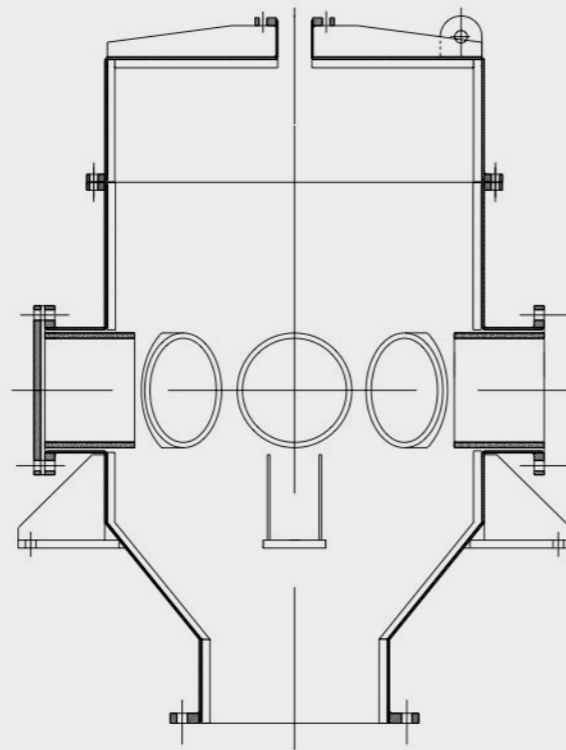

## Hydrocyclones for Reliable Classification



Kalenborn offer a wide material range for optimal economy in the lining of hydrocyclones.



Tailor-made molded parts made of KALSICA N guarantee a long lifetime.



Cyclone lined with KALSICA N silicon carbide ceramics with a diameter of 1,200 mm Ø.



Cyclones lined with KALOCER high alumina ceramics ensure long duty cycles.

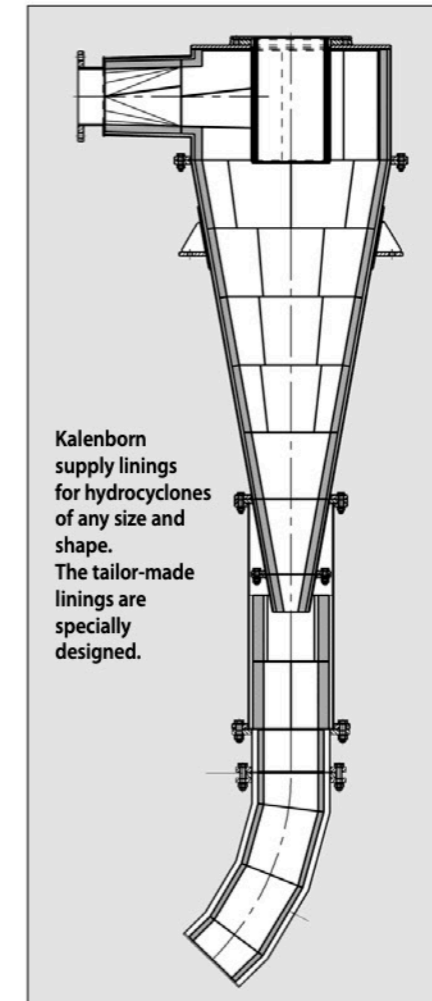

Kalenborn supply linings for hydrocyclones of any size and shape. The tailor-made linings are specially designed.



Self-supporting KALSICA S hydrocyclone structure. The solution is highlighted by minimum dimensions and low weight.



Apex solutions of KALOCER high alumina ceramics can be manufactured in many shapes and dimensions.

# >> Wear Protection for Mining and Processing

## Screens and Mechanical Conveying Equipment



A variety of wear resistant materials are offered for the processing of raw materials. These include both metallic and ceramic materials.

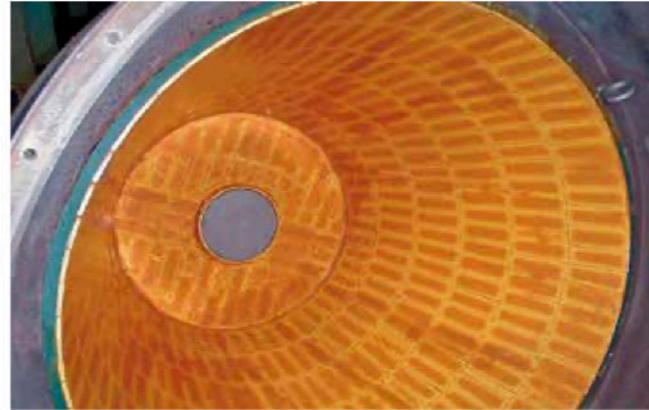

Silo hopper fitted with 25 mm thick KALOCER lining. Due to high requirements on cohesiveness and impact resistance the attachment is fixed with a high performance adhesive.



Screens for many branches of basic industry are economically manufactured of KALMETALL HB hard steel.



Screw conveyors protected against wear by KALMETALL W100; diameter up to 2.000 mm, length up to 10.000 mm.



Reliable protection in a material chute with 62 mm thick KALCAST 155 castings. For improved impact resistance and noise level, an 8 mm thick rubber layer is installed beneath the castings.



Screens are used in many areas of raw material processing. The herringbone pattern is burned in the KALMETALL hard overlay welded plates.



Both sides of the mill charger flights have been lined with KALMETALL W100; 800 mm diameter.

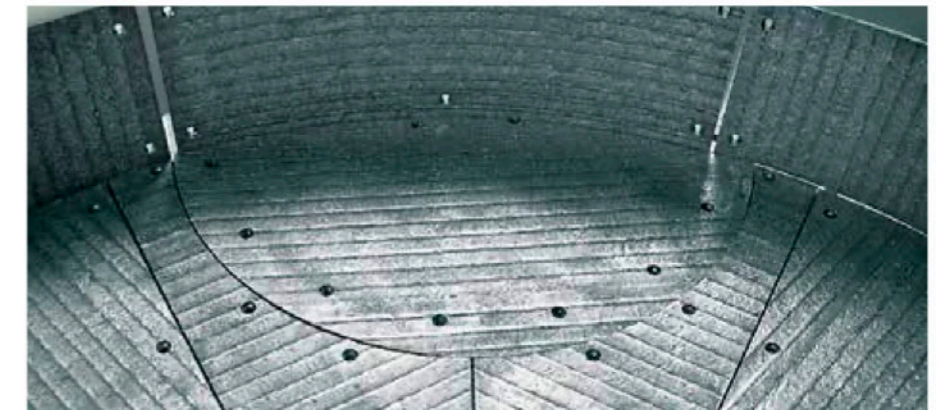

Lining of a mixer: the sidewalls, the bottom and the discharge elements have been protected with KALMETALL W100; diameter 3.500 mm.

Helical chutes are well suited for the careful transport of raw materials, e. g. in coal mining. Kalenborn have many years of practical experience in the design of these conveying systems. The long-life lining is made of KALCAST plates. Other economical solutions are realized using the combination of ceramic and metallic lining materials.

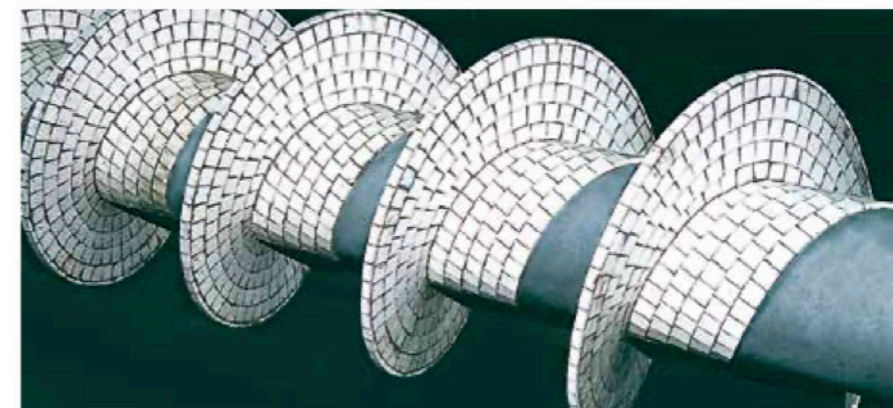
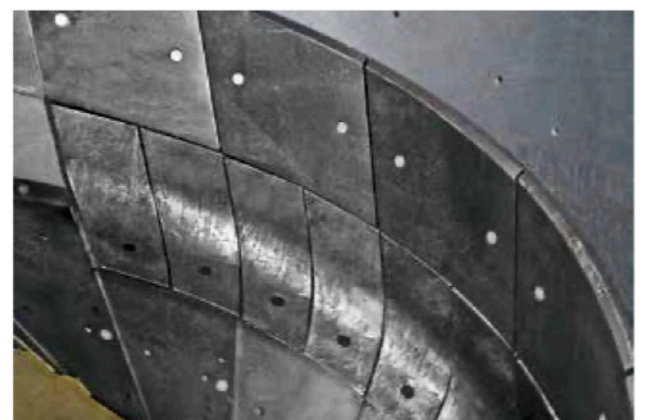

In addition to KALMETALL and KALCAST linings, conveyor screws may also be effectively protected with KALOCER high alumina ceramics. Screw conveyors can have diameters up to 2.000 mm.

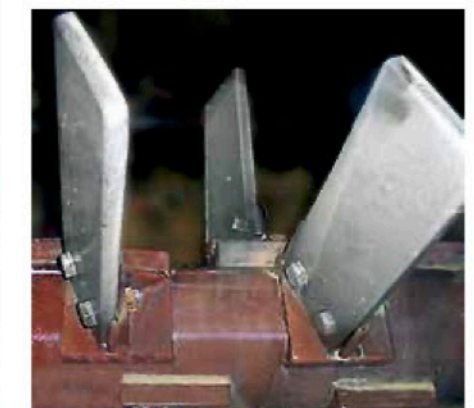

Paddles made of KALCAST 153 for a mineral washing system.

# >> Wear Protection for Mining and Processing

## Long Duty Cycles in Dust Collection Plants



The fine dust that occurs in processing plants is extremely abrasive. This requires the plant components to be carefully protected. It is done both with metallic and ceramic materials.



Fan housings and rotors to be integrated in pneumatic systems are reliably lined with KALMETALL.



Pneumatic transport systems require reliable wear protection – by ABRESIST, KALCOR or KALOCER.



Large diameter dust collection pipes can be cost-effectively manufactured as self-supporting structures of KALMETALL hard overlay welded plates.

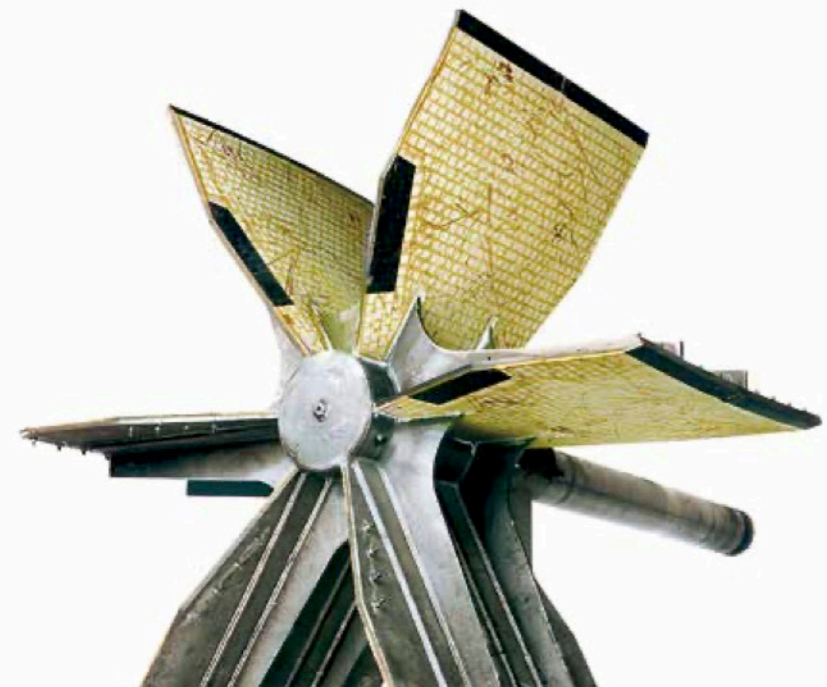

In case of extreme wear, the fan blades can be protected by KALOCER high alumina ceramics. Due to the high rotational speed a high performance adhesive is used.

## Reliable Slide Promotion for Sticky Raw Materials



Slide promotion lining of a silo outlet with KALEN 1000 slide promotion plastics.



Large bunkers are efficiently and reliably lined with KALEN slide promotion plastics.

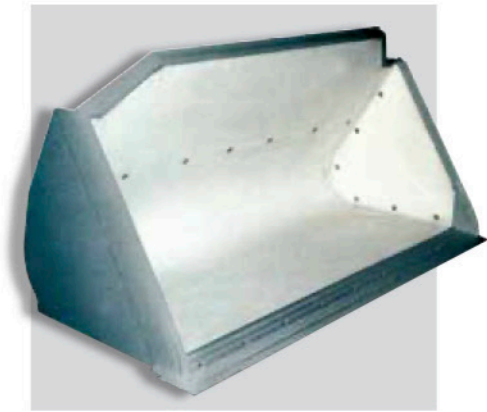

To ensure complete emptying, shovel loaders are successfully lined with KALEN 1000 slide promotion plastics.



The slide promotion lining has raw materials continuously discharged from silos and bunkers without coating or clogging.

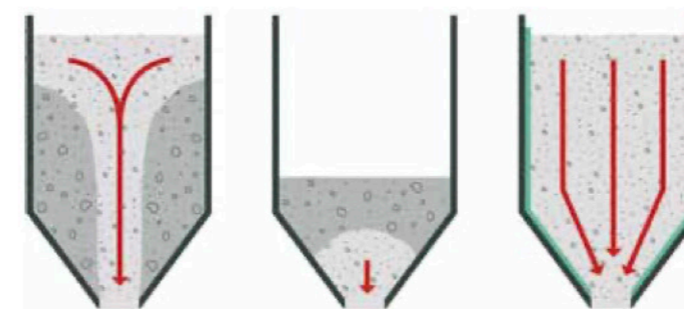

Coatings and core flow

Bridging and material flow interruption

Reliable material and production flow

Flow problems frequently occur when storing and/or transporting fine-grained bulk materials in bunkers, chutes, troughs, silos, shovels, etc. This is particularly true, when these bulk materials are handled and/or stored when moist or wet. The use of slide promotion lining materials – thereby reducing wall friction and avoiding adhesion – yields significant improvements of the flow properties.



## Wear Resistant Linings

Lining	Material Hardness		Process Parameters			Resistance		
	Mohs	Vickers HV 1	Max. conveying speed m/sec.	Max. temperature		Wear resistance	Thermal shock resistance	Impact resistance
				°C	°F			
ABRESIST fused cast basalt	8	770	20	350	662	+++	+	+
KALOCER high alumina ceramics	9	1,050	30	1,000	1,832	++++	+	+
KALCOR zirconium corundum	9	900	30	1,000	1,832	++++	++	++
KALCOR S sintered zirconium corundum	9	970	25	1,200	2,192	+++	+++	++
KALSICA N silicon carbide ceramics	9	1,100	25	1,550	2,822	+++	++++	+
KALSICA S silicon carbide ceramics	9	1,600	35	1,250	2,282	++++	++++	++
KALCERAM wear-resistant hard ceramic	7	500	20	350	662	++	+	+
KALCRET hard compound	8	1,250 *	20	1,200	2,192	++++	++	++
KALMETALL W100 hard overlay welding	7	700	20	350	662	++++	+++	+++
KALCAST C155 hard casting	7	700	20	350	662	++++	+++	++

\* referred to the hard aggregate material

## Slide Promotion Linings

Lining	Slide Promotion	Max. Temperature		Wear Resistance
		°C	°F	
KALEN slide promotion plastics	+++++	80	176	+
KALCERAM wear-resistant hard ceramic	+++	350	662	++
ABRESIST fused cast basalt	+++	350	662	+++

### DGC SOUTH AFRICA

DICKINSON FURNANCE SERVICES (PTY) LTD  
DICKINSON INDUSTRIES (PTY) LTD

T +27 (0) 16 421 3720  
F +27 (0) 16 422 1038  
E sales@dgrpint.com

10 Smuts Avenue, Vereeniging  
P.O. Box 63, Vereeniging, South Africa, 1930

www.dgrpint.com

### INTERNATIONAL

DGC INTERNATIONAL LTD

T +230 403 2500  
E sales@dgrpint.com  
2nd Floor, The AXIS, 26 Bank Street,  
Cybercity, Ebene, 72201, Mauritius



### DGC AFRICA

DICKINSON COPPERBELT SERVICES LTD  
DGC AFRICA (DRC) S.A.S  
DGC STAFFING SOLUTIONS

T +260 76 183 2470 (Zambia)  
E sales@dgc-africa.com

OFFICES:  
Mufulira, Zambia  
Lubumbashi, Democratic Republic of Congo

www.dgc-africa.com

### Kalenborn

Asbacher Str. 50  
D-53560 Vettelschoss

Phone: +49 (0)2645 18-0

kalenborn@kalenborn.com  
www.kalenborn.com



ABRESIST, KALCERAM, KALCOR, KALCRET, KALEN, KALENBORN, KALFIX, KALINOX, KALMETALL, KALOCER, KALPOXY, KALPROTECT, KALCAST, KALIMPACT, KALRESIST and KALSICA are trademarks of Kalenborn.

This brochure and other technical information are general only. They do not cover any guarantee with legal effect. Technical changes and errors are reserved.